

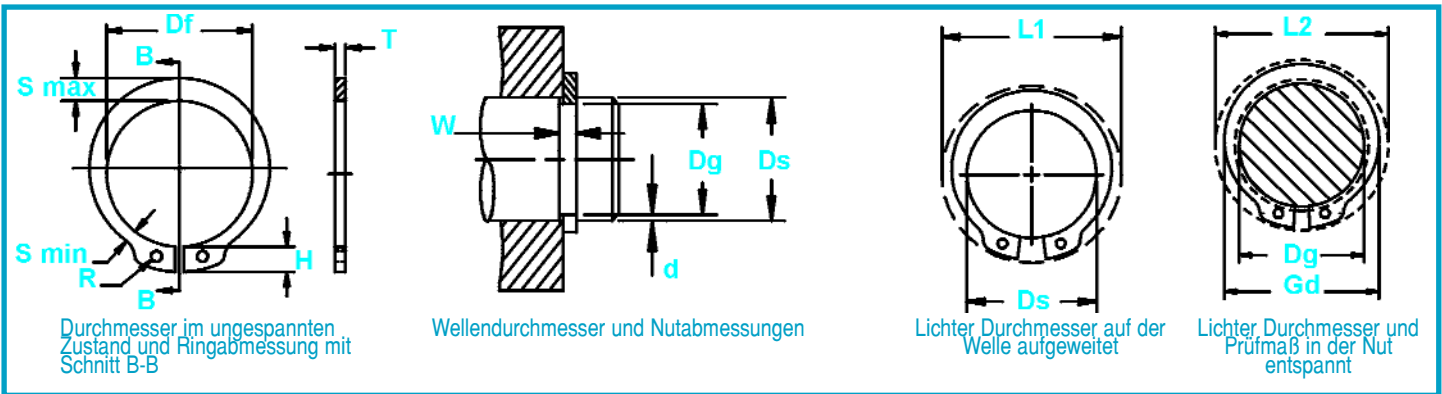

MSR Sicherungsringe für Wellen



RING NR.	WELLE		NUTGRÖßE					RINGGRÖßE UND GEWICHT					LICHTER DURCHM.		i AXIALBELASTUNG (kN) bei rechtwinkliger Anlage		
	DURCHMESSER		DURCHMESSER		BREITE	TIEFE	Durchmesser im ungespannten Zustand		DICKE***		Gewicht pro 1000 Stck.	Auf der Welle aufgeweitet	In der Nut entspannt	Ring Sicherheitsfaktor 4	Nut Sicherheitsfaktor 2		
	Ds mm	Ds INCH	Dg	tol	F.I.M.**	W	tol	d	Df	tol	T	tol	kg	L1	L2	Pr	Pg
MSR-10	10	0.393	9.40	-0.08	0.05	1.00	+0.15	0.30	9.20	+0.08	0.9	±0.06	0.32	15.6	14.8	9.3	2.9
MSR-11	11	0.433	10.30		0.05	1.00		0.35	10.00	-0.20	0.9		0.39	16.6	15.8	10.8	3.8
MSR-12	12	0.472	11.30	-0.10	0.05	1.20	+0.15	0.35	11.05	+0.13	1.1	±0.06	0.63	17.6	16.8	13.7	4.0
MSR-13	13	0.512	12.20		0.05	1.40		0.40	11.80		1.3		0.72	19.5	18.5	17.6	5.0
MSR-14	14	0.551	13.15	-0.10	0.05	1.40	+0.15	0.43	12.80	+0.13	1.3	±0.06	0.80	20.5	19.5	18.9	5.8
MSR-15	15	0.591	14.10		0.05	1.40		0.45	13.80		1.3		1.00	22.1	21.1	20.3	6.5
MSR-16	16	0.630	15.00	-0.10	0.08	1.40	+0.15	0.50	14.70	+0.13	1.3	±0.06	1.04	23.2	22.0	21.6	7.7
MSR-17	17	0.669	15.95		0.08	1.40		0.53	15.65		-0.25		1.2	24.2	22.9	23.0	8.7
MSR-18	18	0.708	16.85	-0.10	0.08	1.75	+0.15	0.58	16.55	+0.13	1.6	±0.06	1.9	26.8	25.5	30.0	10.0
MSR-19	19	0.748	17.80		0.08	2.15		0.60	17.50		2.0		2.5	28.8	27.4	40.0	11.0
MSR-20	20	0.787	18.75	-0.10	0.08	2.15	+0.15	0.63	18.45	+0.13	2.0	±0.06	2.8	29.8	28.4	42.0	13.1
MSR-22	22	0.866	20.70		0.08	2.15		0.65	20.40		2.0		3.4	31.9	30.4	46.0	13.7
MSR-25	25	0.984	23.50	-0.10	0.08	2.15	+0.15	0.75	23.10	+0.13	2.0	±0.06	3.5	34.9	33.1	52.0	18.0
MSR-27	27	1.063	25.40		0.10	2.55		0.80	24.85		2.4		5.2	39.0	37.1	67.0	20.8
MSR-28	28	1.102	26.30	-0.15	0.10	2.55	+0.20	0.85	25.70	+0.25	2.4	±0.08	5.6	40.0	38.0	69.0	22.8
MSR-30	30	1.181	28.20		0.10	2.55		0.90	27.60		2.4		6.1	42.0	40.0	74.0	26.0
MSR-32	32	1.260	30.00	-0.15	0.10	2.55	+0.20	1.00	29.35	-0.40	2.4	±0.08	6.8	44.1	41.8	79.0	30.8
MSR-35	35	1.378	32.80		0.10	2.55		1.10	32.20		2.4		8.1	47.1	44.6	87.0	38.0
MSR-38	38	1.496	35.60	-0.20	0.10	2.95	+0.25	1.20	35.05	+0.35	2.8	±0.10	12.2	53.2	50.5	111.0	44.0
MSR-40	40	1.575	37.50		0.15	2.95		1.25	36.70		2.8		14.1	55.2	52.4	116.0	48.0
MSR-45	45	1.772	42.20	-0.20	0.15	2.95	+0.25	1.40	41.10	-0.50	2.8	±0.10	15.1	60.9	57.7	130.0	61.0
MSR-50	50	1.969	47.00		0.15	3.40		1.50	45.50		3.2		21.8	67.1	63.8	165.0	72.0

* GESAMTER ANZEIGENAUSSCHLAG - MAXIMAL ZULÄSSIGE RUNDLAUFABWEICHUNG ZWISCHEN NUT UND GEHÄUSE

† BASIEREND AUF GEHÄUSEN/WELLEN AUS KALTGEWALZTEM STAHL. FRAGEN ZU DEN FORMELN, DIE ZUR ABLEITUNG DER AXIALBELASTUNG UND DER ANDEREN LEISTUNGSKENNDATEN VERWENDET WURDEN, BITTE AN DIE ABTEILUNG ROTOR CLIP ENGINEERING RICHTEN.

*** DIE AUFGEFÜHRTE MAXIMALE DICKE BEI GALVANISCH BEHANDELTEN RINGEN ZUZÜGLICH 0,05 mm. DIE MAXIMALE RINGDICKE IST UM MINDESTENS 0,005 mm KLEINER ALS DIE AUFGEFÜHRTE MINIMALE NUTBREITE (W).

Axialmontiert, für Wellen, ANSI Metrisch

Diese verstärkte Version des MSH-Rings kann größere Belastungen aufnehmen.

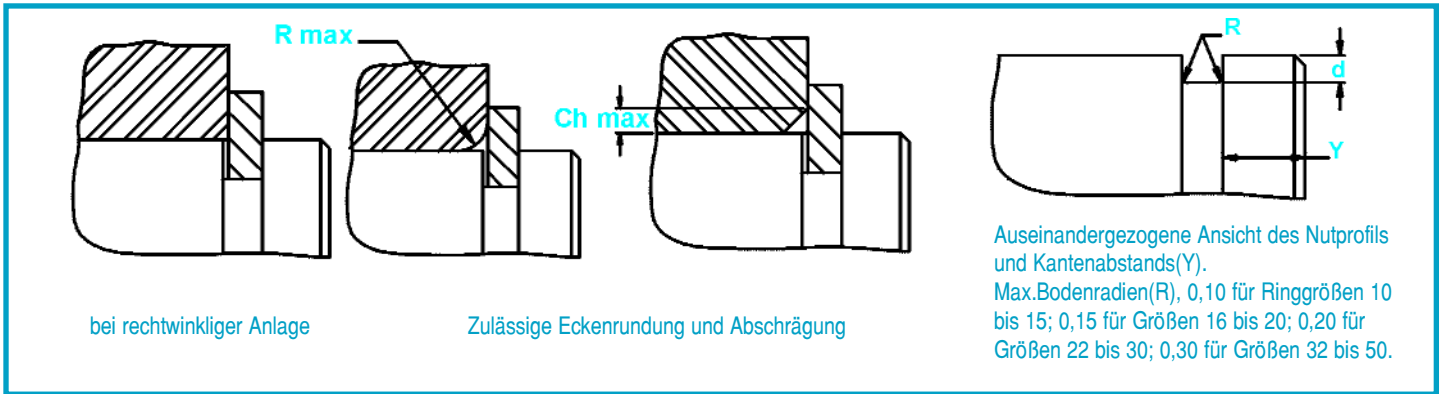

RING NR.	AUGEN HOHE	MAX. Querschnitt	MIN. Querschnitt	MONTAGE-LOCH DURCHMESSER	PRÜFMAß	ZULÄSSIGE ECKENRUNDUNG UND ABSCHRÄGUNG		MAX. BELASTUNG bei R max oder Ch max (kN)	KANTEN-ABSTAND	U/MIN Grenzwerte Standardmaterial
	H nom	S max/Ref.	S min/Ref.	R min		Gd	R max	Ch max	P'r	Y
MSR-10	2.6	1.7	1.0	1.0	12.15	1.0	0.8	2.7	0.9	66000
MSR-11	2.6	1.9	1.1	1.0	13.40	1.0	0.8	3.0	1.0	60000
MSR-12	2.6	2.2	1.3	1.0	14.95	1.6	1.3	3.2	1.0	55000
MSR-13	3.0	2.3	1.3	1.2	15.80	1.6	1.3	4.6	1.2	52000
MSR-14	3.0	2.4	1.4	1.2	16.90	1.6	1.3	4.8	1.3	47000
MSR-15	3.3	2.6	1.4	1.2	18.20	1.6	1.3	5.2	1.3	42000
MSR-16	3.3	2.7	1.5	1.2	19.20	1.6	1.3	5.4	1.5	39000
MSR-17	3.3	2.8	1.6	1.2	20.45	1.6	1.3	5.7	1.6	36000
MSR-18	4.1	3.0	1.8	1.9	21.75	1.8	1.5	8.0	1.7	35000
MSR-19	4.6	3.2	2.0	1.9	23.05	1.8	1.5	13.2	1.8	30000
MSR-20	4.6	3.4	2.0	1.9	24.30	2.0	1.6	13.2	1.9	29000
MSR-22	4.6	3.8	2.1	1.9	26.60	2.0	1.6	14.7	2.0	27000
MSR-25	4.6	3.8	2.1	1.9	29.45	2.0	1.6	14.7	2.2	24000
MSR-27	5.6	4.1	2.3	2.3	32.00	2.0	1.6	22.9	2.4	22000
MSR-28	5.6	4.3	2.4	2.3	33.20	2.0	1.6	24.0	2.5	20000
MSR-30	5.6	4.5	2.5	2.3	35.40	2.0	1.6	25.0	2.7	19000
MSR-32	5.6	4.7	2.6	2.3	37.30	2.5	2.1	19.0	3.0	18000
MSR-35	5.6	5.1	2.8	2.3	40.80	2.5	2.1	22.0	3.3	16000
MSR-38	7.1	5.5	3.1	2.7	44.40	2.5	2.1	32.0	3.6	15000
MSR-40	7.1	5.8	3.2	2.7	46.70	2.5	2.1	34.0	3.7	13500
MSR-45	7.4	6.5	3.6	2.7	52.20	2.5	2.1	38.0	4.2	12500
MSR-50	8.0	7.1	3.9	3.1	58.40	3.5	2.9	39.0	4.5	11000

GRÖßERE GRÖßEN SIND AUF ANFRAGE HIN ERHÄLTICH.

HÄRTEBEREICH: EDELSTAHLRINGE (PH 15-7MO)

RINGSORTE	GRÖßENBEREICH	SKALA	ROCKWELL HÄRTE
MSR	10-16	30N	63-69.5
	17-50	C	44-51

HÄRTEBEREICH: KOHLENSTOFFSTAHL-RINGE (SAE 1060-1090)

RINGSORTE	GRÖßENBEREICH	SKALA	ROCKWELL HÄRTE
MSR	10-16	30N	68.5-72
	17-50	C	48-52