

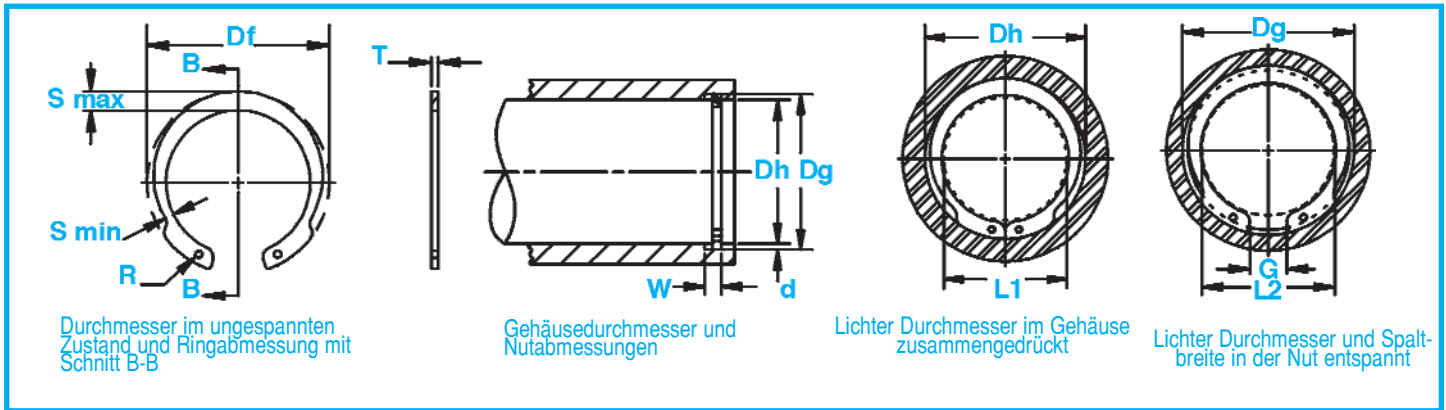

# HOI Sicherungsringe für Bohrungen



RING NR.	GEHÄUSE DURCHMESSER			NUTGRÖßE			RINGGRÖßE & GEWICHT					LICHTER DURCHM.		î AXIALBELASTUNG bei rechtwinkliger Anlage			
	Dh DEZ	Dh BRUCH	Dh mm	DURCHMESSER		BREITE	TIEFE	DURCHMESSER IM UNGESpanNTEN ZUSTAND		DICKE***		GEWICHT PRO 1000 STÜCK	IM GEHÄUSE ZUSAMMENGEDRÜCKT	IN DER NUT ENTSPANNT	Ring-Sicherheitsfaktor 4	Nut-Sicherheitsfaktor 2	
				Dg	Tol.	W	Tol.	d	Df	Tol.	T						Tol.
HOI-62	.625	5/8	15.9	.665	±.002	.029		.020	.675		.025		0.7	.47	.51	1015	450
HOI-75	.750	3/4	19.0	.796	.004*	.039		.023	.808		.035		1.3	.56	.605	1675	600
HOI-81	.812	13/16	20.6	.862		.046	+ .003	.025	.877	+ .010	.042		2.0	.62	.665	2639	700
HOI-87	.875	7/8	22.2	.931	±.003	.046	- .000	.028	.944	- .005	.042		2.2	.65	.705	2893	850
HOI-93	.938	15/16	23.8	1.000	.004*	.046		.031	1.015		.042		2.8	.70	.755	3147	1000
HOI-100	1.000	1	25.4	1.066		.046		.033	1.081		.042		2.9	.75	.81	3350	1150
HOI-106	1.062	1-1/16	27.0	1.130		.056		.034	1.150		.050		3.8	.80	.87	4212	1250
HOI-112	1.125	1-1/8	28.6	1.197		.056		.036	1.217		.050		4.4	.86	.93	4466	1400
HOI-118	1.188	1-3/16	30.2	1.262		.056		.037	1.283	+ .015	.050	±.002	4.9	.91	.98	4720	1600
HOI-125	1.250	1-1/4	31.7	1.330	±.004	.056		.040	1.351	- .010	.050		5.0	.97	1.05	4974	1750
HOI-131	1.312	1-5/16	33.3	1.396	.005*	.056		.042	1.418		.050		5.3	1.02	1.10	5227	1950
HOI-137	1.375	1-3/8	34.9	1.461		.056	+ .004	.043	1.486		.050		5.9	1.08	1.16	5481	2100
HOI-143	1.438	1-7/16	36.5	1.528		.056	- .000	.045	1.552		.050		6.3	1.13	1.22	5735	2300
HOI-150	1.500	1-1/2	38.1	1.594		.056		.047	1.622		.050		6.8	1.18	1.27	5938	2500
HOI-156	1.562	1-9/16	39.7	1.658		.068		.048	1.688		.062		8.9	1.21	1.30	7714	2650
HOI-162	1.625	1-5/8	41.3	1.725		.068		.050	1.756		.062		10.4	1.27	1.37	8019	2850
HOI-168	1.688	1-11/16	42.9	1.792	±.005	.068		.052	1.823	+ .020	.062		11.9	1.32	1.42	8374	3100
HOI-175	1.750	1-3/4	44.4	1.858	.005*	.068		.054	1.891	- .013	.062		11.8	1.38	1.49	8678	3300
HOI-187	1.875	1-7/8	47.6	1.989		.068		.057	2.025		.062		14.8	1.47	1.58	9287	3750
HOI-200	2.000	2	50.8	2.122		.068		.061	2.160		.062		17.4	1.55	1.67	9896	4300
HOI-206	2.062	2-1/16	52.4	2.186		.086		.062	2.224		.078		23.2	1.59	1.71	12840	4500
HOI-212	2.125	2-1/8	54.0	2.251	±.006	.086	+ .005	.063	2.295		.078		24.3	1.65	1.77	13246	4700
HOI-237	2.375	2-3/8	60.3	2.517	.006*	.086	- .000	.071	2.567	+ .025	.078	±.003	28.6	1.86	2.00	14718	5900
HOI-243	2.438	2-7/16	61.9	2.584		.086		.072	2.634	- .015	.078		30.6	1.91	2.05	15124	6200
HOI-250	2.500	2-1/2	63.5	2.648		.086		.074	2.700		.078		32.1	1.96	2.10	15530	6500
HOI-262	2.625	2-5/8	66.7	2.781		.103		.078	2.840		.093		45.6	2.06	2.21	19488	7200
HOI-275	2.750	2-3/4	69.8	2.914		.103		.082	2.975		.093		47.8	2.16	2.32	20300	7900
HOI-283	2.812	2-13/16	71.4	2.980		.103		.084	3.063		.093		49.5	2.21	2.37	20808	8300
HOI-283	2.835	-	72.0	3.006		.103		.086	3.063		.093		49.5	2.23	2.39	20808	8550
HOI-287	2.875	2-7/8	73.0	3.051		.103		.088	3.105	+ .030	.093		50.1	2.26	2.43	21315	8900
HOI-300	3.000	3	76.2	3.182		.103		.091	3.245	- .020	.093		52.6	2.36	2.53	22229	9600
HOI-315	3.156	3-5/32	80.2	3.348		.120		.096	3.408		.109		69.4	2.50	2.69	27405	10600
HOI-325	3.250	3-1/4	82.5	3.446		.120		.098	3.509		.109		72.6	2.58	2.77	28217	11200
HOI-334	3.346	3-11/32	85.0	3.546		.120		.100	3.611		.109		75.6	2.67	2.87	29029	11700
HOI-350	3.500	3-1/2	88.9	3.710		.120		.105	3.780		.109		80.2	2.82	3.03	30349	12900
HOI-356	3.562	3-9/16	90.5	3.776		.120		.107	3.850		.109		82.4	2.88	3.09	30958	13400
HOI-400	4.000	4	101.6	4.240		.120		.120	4.350		.109		97.4	3.29	3.53	34713	16900

GESAMTER ANZEIGENAUSSCHLAG - MAXIMAL ZULÄSSIGE RUNDLAUFABWEICHUNG ZWISCHEN NUT UND GEHÄUSE

î BASIEREND AUF GEHÄUSEN/WELLEN AUS KALTGEWALZTEM STAHL. FRAGEN ZU DEN FORMELN, DIE ZUR ABLEITUNG DER AXIALBELASTUNG UND DER ANDEREN LEISTUNGSKENNDATEN VERWENDET WURDEN, BITTE AN DIE ABTEILUNG ROTOR CLIP ENGINEERING RICHTEN.

\*\*\* DIE AUFGEFÜHRTE MAXIMALE DICKE BEI GALVANISCH BEHANDELTEN RINGEN ZUZÜGLICH 0,002 INCH. DIE MAXIMALE RINGDICKE IST UM MINDESTENS 0,0002 INCH KLEINER ALS DIE AUFGEFÜHRTE MINIMALE NUTBREITE (W).

# Axialmontiert, für Bohrungen

Im Vergleich zum HO-Ring, ist die Einstecktiefe der Augen dieses Ringes reduziert und bietet daher mehr Spielraum.

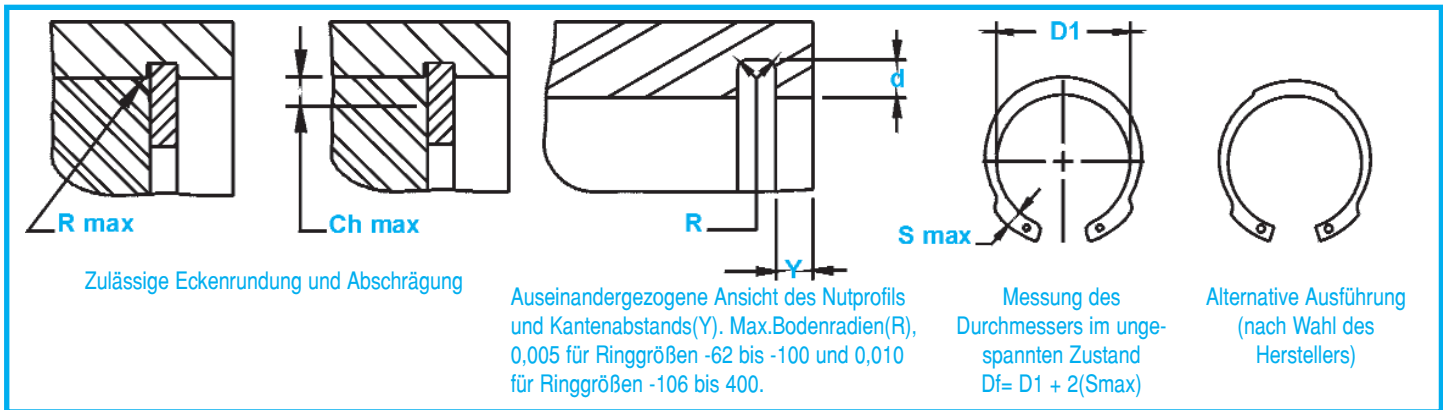

RING NR.	MAXIMALER QUERSCHNITT		MINIMALER QUERSCHNITT		MONTAGELOCH DURCHMESSR		SPALTBREITE Ring in Nut	ZULÄSSIGE ECKENRUNDUNG UND ABSCHRÄGUNG			MAX. BELASTUNG bei R max or Ch max (lbs.)	KANTEN-ABSTAND
	S max	Tol.	S min	Tol.	R	Tol.		G Min	R max	Ch max		
HOI-62	.072	±.004	.036	±.004	.030		.16	.042	.028	400	.060	
HOI-75	.085		.042		.042		.165	.050	.031	850	.069	
HOI-81	.092		.044		.042		.18	.054	.034	1250	.075	
HOI-87	.099		.047		.042		.19	.057	.036	1250	.084	
HOI-93	.106	±.005	.051	±.005	.042	+ .010	.22	.060	.038	1250	.093	
HOI-100	.113		.054		.042	- .002	.235	.064	.040	1250	.099	
HOI-106	.120		.057		.050		.22	.069	.043	1800	.102	
HOI-112	.123		.059		.050		.245	.070	.044	1800	.108	
HOI-118	.126		.060		.050		.26	.071	.045	1800	.111	
HOI-125	.129	±.006	.061	±.006	.050		.28	.071	.045	1800	.120	
HOI-131	.132		.063		.050		.29	.072	.045	1800	.126	
HOI-137	.135		.065		.050		.33	.074	.046	1800	.129	
HOI-143	.144		.069		.076		.35	.079	.050	1800	.135	
HOI-150	.148		.070		.076		.33	.081	.051	1800	.141	
HOI-156	.158		.074		.076		.36	.088	.055	2900	.144	
HOI-162	.162		.077		.076		.385	.090	.056	2900	.150	
HOI-168	.166	±.007	.079	±.007	.076	+ .015	.405	.091	.057	2900	.156	
HOI-175	.170		.082		.076	- .002	.42	.093	.058	2900	.162	
HOI-187	.188		.090		.076		.44	.105	.066	2900	.171	
HOI-200	.208		.100		.076		.48	.118	.074	2900	.183	
HOI-206	.218		.106		.094		.485	.125	.078	4600	.186	
HOI-212	.223		.108		.094		.49	.128	.080	4600	.189	
HOI-237	.243		.115		.094		.55	.138	.086	4600	.213	
HOI-243	.248		.117		.094		.57	.141	.088	4600	.216	
HOI-250	.254		.120		.094		.59	.144	.090	4600	.222	
HOI-262	.266		.128		.109		.60	.150	.094	6700	.234	
HOI-275	.278		.134		.109		.63	.157	.098	6700	.246	
HOI-283	.286		.139		.109		.61	.162	.102	6700	.252	
HOI-283	.286		.139		.109		.67	.162	.102	6700	.258	
HOI-287	.290		.139		.109		-	.162	.101	6700	.264	
HOI-300	.302		.143		.109		.705	.169	.106	6700	.273	
HOI-315	.314		.149		.125		.76	.174	.109	9000	.288	
HOI-325	.318		.151		.125		-	.176	.110	9000	.294	
HOI-334	.321	±.008	.155	±.008	.125		.81	.177	.111	9000	.300	
HOI-350	.324		.154		.125		.84	.175	.110	9000	.315	
HOI-356	.326		.155		.125		.86	.175	.110	9000	.321	
HOI-400	.338		.161		.125		.93	.174	.108	9000	.360	

HÄRTEBEREICH: KOHLENSTOFFSTAHL-RINGE (SAE 1060-1090)

RINGSORTE	GRÖßENBEREICH	SKALA	ROCKWELL HÄRTE
HOI	62 & 75	30N	67.5-72
	81-100	30N	66-71
	106-343	C	47-52
	350+	C	45-50

HÄRTEBEREICH: EDELSTAHLRINGE (PH 15-7MO)

RINGSORTE	GRÖßENBEREICH	SKALA	ROCKWELL HÄRTE
HOI	62-100	30N	63-69.5
	106+	C	44-51

HÄRTEBEREICH: BERYLLIUM-KUPFERRINGE

RINGSORTE	GRÖßENBEREICH	SKALA	ROCKWELL HÄRTE
HOI	62-100	30N	56.5-62
	106+	C	37-43