

MCG Spiral Shaft Rings

External, Heavy Duty, Metric

The rigors of the toughest applications are easily handled by this external series. Its large size, and ease of application and removal, transfers into an assurance of quality for demanding uses.

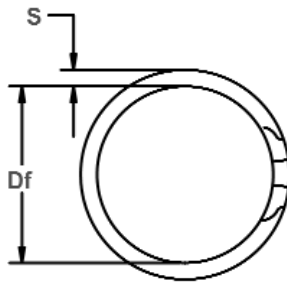

Free Diameter & Ring Measurements

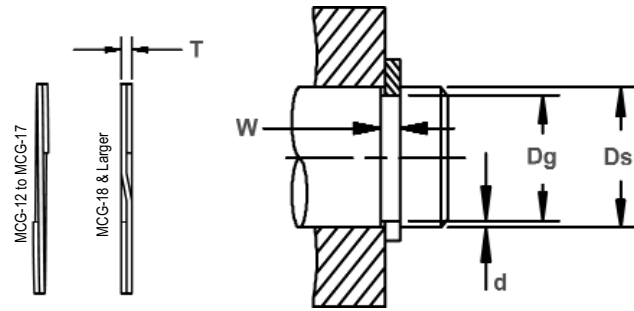

Shaft Diameter & Groove Dimensions

RING NO.	SHAFT DIAMETER (mm)	GROOVE SIZE				RING SIZE						THRUST LOAD (N)	
		DIAMETER		WIDTH		FREE DIAMETER		THICKNESS		SECTION		RING Safety factor of 3	GROOVE Safety factor of 2
		Dg	Tol.	W	Tol.	Df	Tol.	T	Tol.	S	Tol.		
MCG-12	12	11.29		0.70		11.18		0.60		1.14		7954	2461
MCG-13	13	12.24	+0.06	1.00		12.13		0.89		1.27		11528	1930
MCG-14	14	13.19	-0.06	1.00		13.06		0.89		1.27		12415	2384
MCG-15	15	14.09		1.00		13.98		0.89		1.27		13302	3181
MCG-16	16	15.03		1.00		14.90		0.89		1.40		14188	3811
MCG-17	17	16.03		1.00		15.82		0.89		1.40		15075	4107
MCG-18	18	16.93		1.20		16.80		1.07		1.65		19190	4561
MCG-19	19	17.88		1.20	+0.08	17.73		1.07		1.65		20256	5309
MCG-20	20	18.78	+0.07	1.20	-0.00	18.62		1.07		1.65		21323	6427
MCG-21	21	19.73	-0.07	1.20		19.57		1.07		1.65		22389	7470
MCG-22	22	20.63		1.20		20.45	+0.00	1.07	+0.05	1.91	+0.08	23455	8686
MCG-23	23	21.58		1.20		21.39	-0.33	1.07	-0.05	1.91	-0.13	24521	9906
MCG-24	24	22.53		1.20		22.35		1.07		1.91		25587	11366
MCG-25	25	23.43		1.20		23.25		1.07		2.16		26653	13132
MCG-26	26	24.43		1.20		24.21		1.07		2.16		27719	14085
MCG-27	27	25.35		1.40		25.04		1.27		2.62		31195	10968
MCG-28	28	26.30		1.40		26.00		1.27		2.62		32350	12439
MCG-29	29	27.27		1.40		26.95		1.27		2.62		33506	13626
MCG-30	30	28.25	+0.10	1.40	+0.10	27.92		1.27		2.62		34661	14898
MCG-31	31	29.17	-0.10	1.40	-0.00	28.84		1.27		2.62		35817	16835
MCG-32	32	30.10		1.40		29.77		1.27		2.62		36972	18840
MCG-34	34	31.90		1.40		31.54		1.27		3.00		39283	23123
MCG-35	35	32.80		1.40		32.44		1.27		3.00		40438	25932
MCG-36	36	33.75		1.40		33.40		1.27		3.00		41593	27964
MCG-37	37	34.67	+0.15	1.40		34.24		1.27		3.00		42749	29763
MCG-38	38	35.65	-0.15	1.40		35.18		1.27		3.00		43904	30830

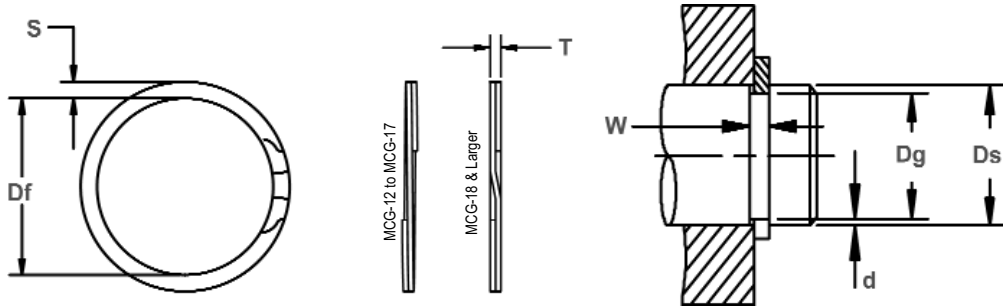

Free Diameter & Ring Measurements

Shaft Diameter & Groove Dimensions

RING NO.	SHAFT DIAMETER (mm)	GROOVE SIZE				RING SIZE						THRUST LOAD (N)	
		DIAMETER		WIDTH		FREE DIAMETER		THICKNESS		SECTION		RING Safety factor of 3	GROOVE Safety factor of 2
		Dg	Tol.	W	Tol.	Df	Tol.	T	Tol.	S	Tol.		
MCG-40	40	37.55		1.75		37.15		1.57		3.25		57132	30470
MCG-42	42	39.45		1.75		39.02		1.57		3.25		59988	35208
MCG-45	45	42.25		1.75	+0.10	41.77	+0.00	1.57		3.25	+0.08	64273	42723
MCG-46	46	43.15	+0.15	1.75	-0.00	42.67	-0.51	1.57		3.25	-0.13	65701	45261
MCG-47	47	44.31		1.75		43.81		1.57		4.01		67130	43649
MCG-48	48	45.05		1.75		44.48		1.57		4.01		68558	48886
MCG-50	50	47.05		1.75		46.69		1.57		4.01		71415	50923
MCG-52	52	48.95		2.15		48.60		1.98		4.27		93667	53451
MCG-54	54	50.85		2.15		50.52		1.98		4.27		97270	58725
MCG-55	55	51.65		2.15		51.26		1.98		4.27		99071	63610
MCG-57	57	53.60		2.15		53.17	+0.00	1.98		4.27		102673	66907
MCG-58	58	54.50		2.15		54.08	-0.64	1.98	+0.08	4.27		104475	70084
MCG-60	60	56.50		2.15		56.05		1.98	-0.08	5.08		108077	72500
MCG-62	62	58.40		2.15		57.99		1.98		5.08		111680	77057
MCG-65	65	61.40		2.15		60.92		1.98		5.08		117084	80786
MCG-68	68	64.30		2.15	+0.13	63.80		1.98		5.08	+0.10	122488	86862
MCG-70	70	66.20		2.55	-0.00	65.70		2.29		5.72	-0.15	138887	91834
MCG-72	72	68.10	+0.20	2.55		67.57		2.29		5.72		142855	96943
MCG-75	75	71.00	-0.20	2.55		70.47	+0.00	2.29		5.72		148808	103572
MCG-78	78	73.80		2.55		73.25	-0.76	2.29		5.72		154760	113101
MCG-80	80	75.70		2.55		75.12		2.29		5.72		158728	118762
MCG-82	82	77.60		2.55		77.00		2.29		5.72		162696	124562
MCG-85	85	80.40		2.55		79.79		2.29		5.72		168649	134989
MCG-88	88	83.30		2.95		82.67		2.72		6.86		207386	142791
MCG-90	90	85.20		2.95		84.54	+0.00	2.72		6.86		212110	149144
MCG-95	95	90.00		2.95		89.32	-0.89	2.72		6.86		223883	163989
MCG-100	100	94.80		2.95		94.09		2.72		6.86		235666	179525