

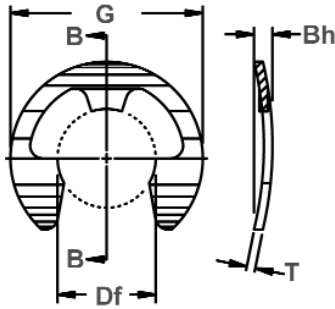

# BE Shaft Rings

## Radially Assembled, External Bowed 'E'

Compensating for accumulated tolerances is what a BE "Bowed" retaining ring is designed to do on a shaft. Once snapped into the groove, bowed rings exert a force or a "preload" on the retained parts for the range specified.



Free Diameter & Ring Measurements  
With Section B-B

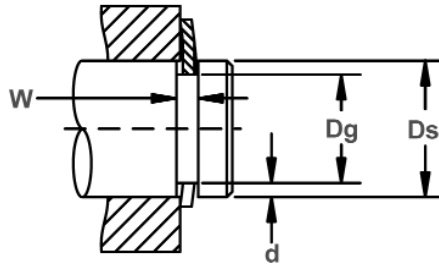

Shaft Diameter &  
Groove Dimensions

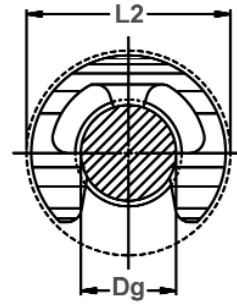

Clearance Diameter  
Installed In Groove

RING NO.	SHAFT DIAMETER			GROOVE SIZE			RING SIZE AND WEIGHT					CLEARANCE DIAMETER					
				DIAMETER		WIDTH	DEPTH	FREE DIAMETER	THICKNESS***		BOW HEIGHT		Weight Per 1000 Pcs.	Out-side dia. REF.	Installed in groove		
	Ds DEC	Ds FRACT	Ds mm	Dg	Tol.	W	Tol.	d	Df	Tol.	T	Tol.	Bh min.	Bh max.	lbs.	G	L2
BSE-11	.110	7/64	2.8	.079	+.002	.022		.015	.076		.010		.025	.035	.20	.375	.390
BE-12	.125	1/8	3.2	.095	-.000	.022		.015	.094		.010	±.001	.025	.035	.06	.230	.240
BSE-14	.140	9/64	3.6	.102	.0015*	.019		.019	.100		.010		.022	.032	.040	.203	.215
BE-14	.140	9/64	3.6	.105		.025		.017	.102		.015		.028	.038	.13	.270	.285
BE-15	.156	5/32	4.0	.116		.027		.020	.114	+.001	.015		.030	.040	.13	.282	.295
BSE-17	.172	11/64	4.4	.127	+.002	.029		.022	.125		.015		.032	.042	.16	.312	.325
BE-18	.188	3/16	4.8	.147	-.000	.030		.020	.145		.015		.033	.043	.17	.335	.35
BSE-18	.188	3/16	4.8	.125	.002*	.035	+.003	.031	.122		.015		.038	.048	.27	.375	.39
BSE-21	.219	7/32	5.6	.188		.040	-.000	.015	.185		.015		.043	.058	.28	.437	.45
BE-25	.250	1/4	6.3	.210		.047		.020	.207		.025		.050	.065	.76	.527	.54
BSE-31	.312	5/16	7.9	.250		.047		.031	.243	+.002	.025	±.002	.050	.065	.57	.500	.52
BE-37	.375	3/8	9.5	.303		.060		.036	.300	-.004	.035		.060	.076	1.5	.660	.68
BE-43	.438	7/16	11.1	.343		.060		.047	.337		.035		.060	.076	1.5	.687	.71
BSE-43	.438	7/16	11.1	.380	+.003	.057		.029	.375		.035		.060	.076	1.0	.600	.62
BE-50	.500	1/2	12.7	.396	-.000	.073		.052	.392		.042		.075	.093	2.5	.800	.82
BE-62	.625	5/8	15.9	.485	.004*	.077		.070	.480		.042		.080	.098	3.2	.940	.96
BSE-74	.744	-	18.9	.625		.085		.060	.616		.050		.090	.110	4.3	1.000	1.02
BSE-74	.750	3/4	19.0	.625		.085		.062	.616		.050		.090	.110	4.3	1.000	1.02
BE-75	.750	3/4	19.0	.580		.085		.085	.574	+.003	.050		.090	.110	5.8	1.120	1.14
BE-87	.875	7/8	22.2	.675		.085		.100	.668	-.005	.050		.090	.110	7.6	1.300	1.32
BSE-98	.984	63/64	25	.835		.085		.074	.822		.050		.088	.112	9.38	1.500	1.530

\*F.I.M. (FULL INDICATOR MOVEMENT)-MAXIMUM ALLOWABLE DEVIATION OF CONCENTRICITY BETWEEN GROOVE AND SHAFT.

\*\*\*FOR PLATED RINGS, ADD .002" TO THE LISTED MAXIMUM THICKNESS.

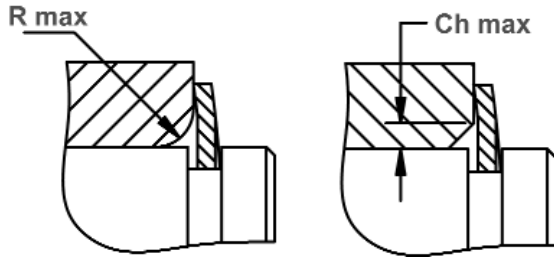

Maximum Corner Radius & Chamfer

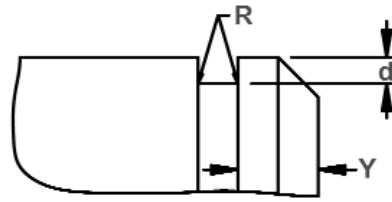

Exploded Groove Profile & Edge Margin (Y)  
Maximum bottom radii (R), .005 For ring sizes BSE-11 Thru -25; 010 For ring sizes BSE-31 Thru BSE-43; .015 For ring sizes 50 and over.

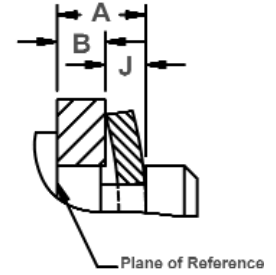

Outer Groove Wall Location  
A max=B min + J max  
A min=B max + J min

RING NO.	DISTANCE Outer groove wall to face of retained part		TAKE-UP Resilient take-up of tolerances a & b	FORCE Needed to flatten rings	ALLOWABLE CORNER RADII & CHAMFERS		MAX. LOAD w/ R max or Ch max (in lbs.)	EDGE MARGIN	R.P.M LIMITS Standard materials	i THRUST LD. (lbs.) Sqr. corner abutment	
					R max	Ch max				Ring Safety factor of 3	Groove Safety factor of 2
	J min	J max	J max-J min	lbs.	R max	Ch max	(lbs.)	Y	Pr	Pg	
BSE-11	.017	.022	.005	19	.080	.060	60	.030	35000	61	40
BE-12	.017	.022	.005	8	.040	.030	43	.030	35000	44	45
BSE-14	.014	.018	.004	6	.029	.022	50	.038	32000	51	60
BE-14	.020	.023	.003	16	.060	.045	75	.034	32000	76	60
BE-15	.022	.027	.005	15	.060	.045	80	.040	31000	81	75
BSE-17	.023	.029	.006	14	.060	.045	90	.044	30000	91	90
BE-18	.023	.030	.007	12	.060	.045	95	.040	30000	96	90
BSE-18	.026	.034	.008	16	.060	.045	100	.062	30000	102	135
BSE-21	.029	.039	.010	12	.060	.045	115	.030	26000	117	75
BE-25	.036	.046	.010	35	.060	.045	255	.040	25000	259	115
BSE-31	.036	.046	.010	30	.060	.045	325	.062	22000	330	225
BE-37	.045	.055	.010	55	.065	.050	690	.072	20000	700	315
BE-43	.045	.055	.010	50	.065	.050	830	.094	16500	842	480
BSE-43	.045	.055	.010	65	.050	.035	800	.058	16500	812	280
BE-50	.056	.070	.014	90	.080	.060	1110	.104	14000	1127	600
BE-62	.061	.075	.014	85	.080	.060	1420	.140	12000	1441	1050
BSE-74	.069	.085	.016	110	.057	.062	1900	.118	11000	1940	1050
BSE-74	.069	.085	.016	110	.042	.062	1900	.124	11000	1979	1100
BE-75	.069	.085	.016	110	.085	.065	2000	.170	10500	2030	1500
BE-87	.069	.085	.016	120	.085	.065	2350	.200	9000	2385	2050
BSE-98	.067	.083	.016	110	.085	.065	2700	.148	6500	2600	1750

i BASED ON HOUSINGS/SHAFTS MADE OF COLD ROLLED STEEL. FOR AN EXPLANATION OF FORMULAS USED TO DERIVE THRUST LOAD AND OTHER PERFORMANCE DATA PLEASE CONTACT THE ROTOR CLIP ENGINEERING DEPARTMENT. LARGER SIZES MAY BE AVAILABLE UPON REQUEST.

HARDNESS RANGES: STAINLESS STEEL RINGS (PH 15-7MO)

RING TYPE	SIZE RANGE	SCALE	ROCKWELL HARDNESS
BE	BE12-BSE14	15N	82.5-86*
	BSE11, BE14-BSE21	15N	82.5-86
	BE25-BSE31	30N	63-69.5
	BE37+	C	44-51

\*HARDNESS CAN NOT BE CHECKED WITH ANY DEGREE OF ACCURACY DIRECTLY ON THESE RINGS.

HARDNESS RANGES: CARBON STEEL RINGS (SAE 1060-1090)

RING TYPE	SIZE RANGE	SCALE	ROCKWELL HARDNESS
BE All	BSE12-BSE14	15N	84.5-87*
	BSE11, BE14-BSE21	15N	84.5-87
	BE25-BSE31	30N	66.5-71
	BE37+	C	47-52

\*HARDNESS CAN NOT BE CHECKED WITH ANY DEGREE OF ACCURACY DIRECTLY ON THESE RINGS.

HARDNESS RANGES: BERYLLIUM COPPER RINGS

RING TYPE	SIZE RANGE	SCALE	ROCKWELL HARDNESS
BE	BE12-BSE14	15N	77-82*
	BSE11, BE14-BSE21	15N	77-82
	BE25&BSE31	30N	54-62
	BE37+	C	34-43

\*HARDNESS CAN NOT BE CHECKED WITH ANY DEGREE OF ACCURACY DIRECTLY ON THESE RINGS.

